



# Operational Excellence Services

## Reliability & Maintenance Risk-Based Inspection (RBI)



### Contact Us

[Technology Inquiries](#) | [Contact Us](#) | [JGC HOLDINGS CORPORATION](#)

### Access to Our Homepage

<https://www.jgc.com/en/business/epc/operation-maintenance/service/>

# Risk-Based Inspection(RBI)

## Do you have any of these issues?

- ☹️ **Many Reliability Incident**
- ☹️ **High Maintenance and Inspection Cost**
- ☹️ **High Insurance Fee**

## RBI Solution

- Determined Risk with probability and consequence of failure
- Prioritized and effective inspection based on risk assessment to static equipment, piping
- Improved reliability whilst reduced maintenance & inspections cost and insurance fee

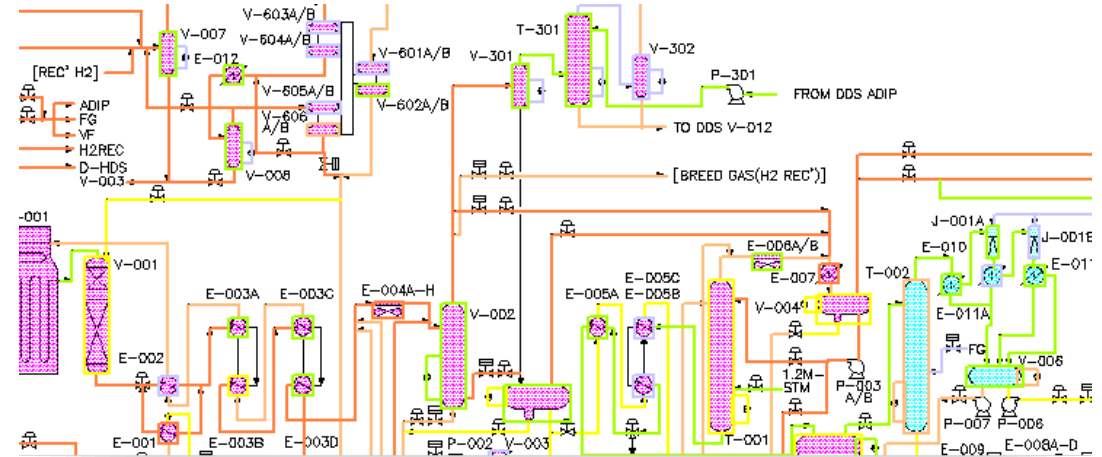

Corrosion Loop Marking

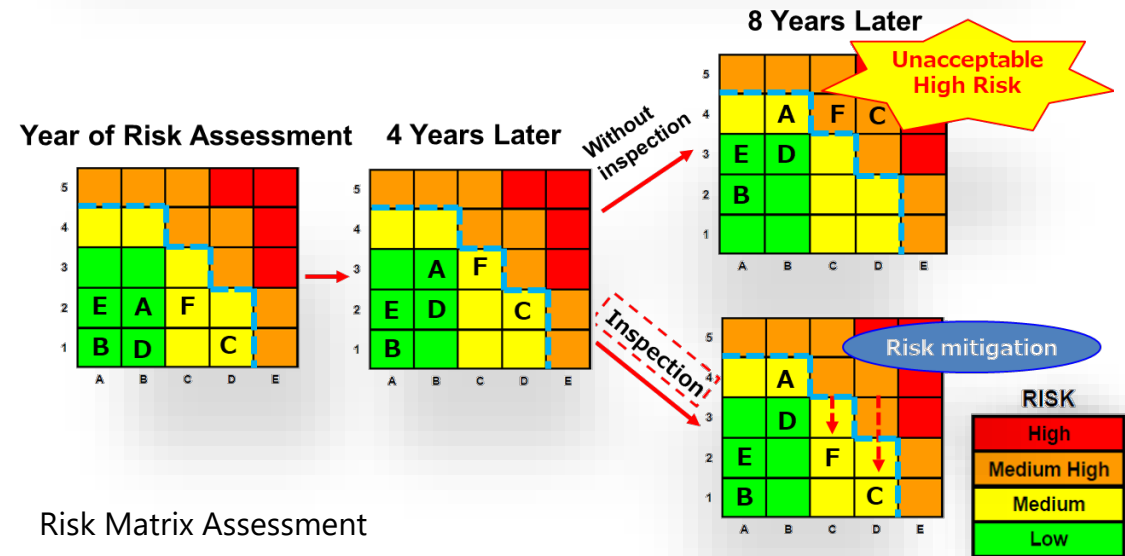

Risk Matrix Assessment

# Risk-Based Inspection(RBI)

Return to  
Reliability &  
Maintenance menu

## Workflow & Result

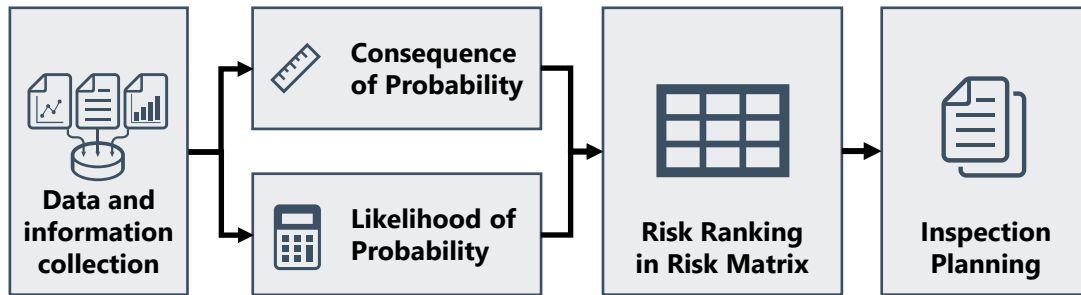

- Evaluation of the Potential Risks
- Development of Inspection Task Plan
- Development of Computerized Maintenance and Inspection System
- Development of Integrity Operating Window

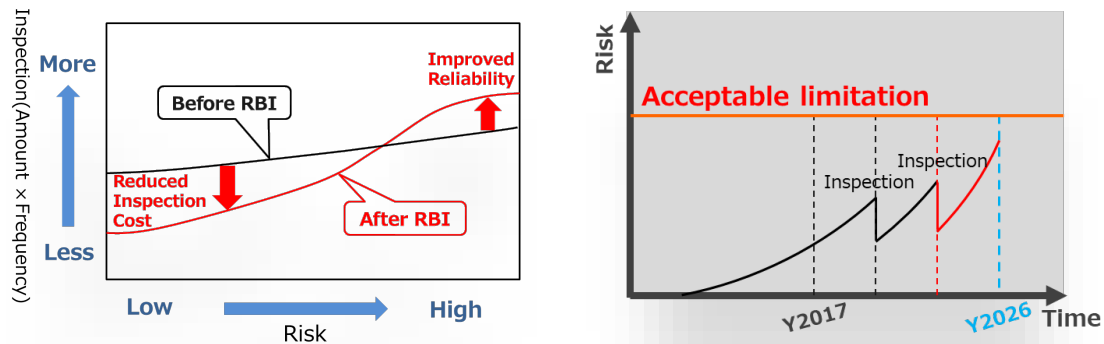

Reduced inspections and cost cuts with RBI

## Our Strengths

- Professional Process and Material Engineer Teams
- Global experiences and performances on risk assessment, inspection planning, on-site Inspection.
- Integrating JGC's many years of inspection and plant design experience to achieve lower inspection costs and longer plant life
- Collaboration between overseas EPC-capable group companies and local maintenance companies.

## Our Experiences

**Worldwide  
Achievement**

RBI Experience in Far East,  
Middle East, Southeast Asia,  
Africa, North America

**15+  
Project**

Refinery, GTL, Gas Processing,  
Gas Oil Separation, FLNG,  
LNG, LNG Terminal